



AVAILABLE IN
LEFT VERSION
SW12SSX



1946

SW12S ELECTRIC CUTTING UNIT

SW12S. Professional cutting unit for Textile & Technical Textile applications.



1946

ELECTRIC CUTTING UNIT SW12S

WHAT'S NEW:

New main power switch with Led
Easy fixing structure for O.E.M applications
Low-friction Teflon® coated foot

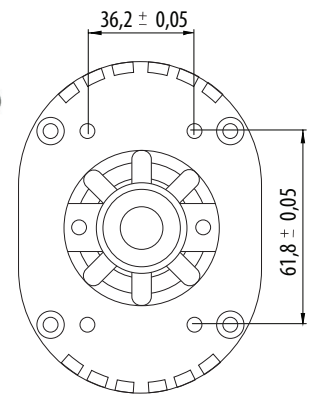
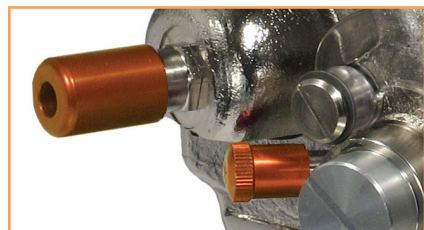
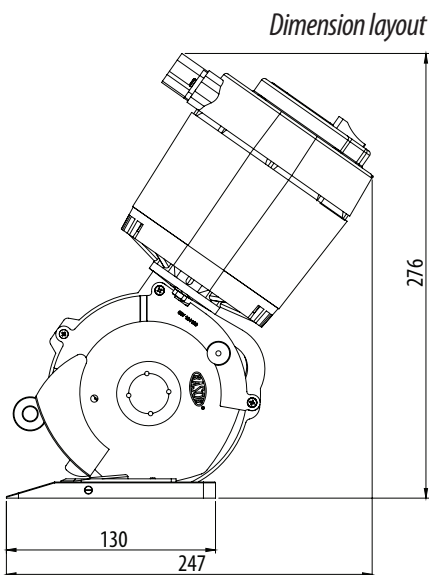

TECHNICAL DETAILS:

Fixing layout

- Blade diameter:** 120 mm (4.7"), with hard metal counterblade
- Blade equipped:** 12SHSS, 8-edges, HSS steel
- Blade speed:** 850 r.p.m.
- Cutting ability:** up to 50 mm (2")
- Power:** single phase – 180 W
- Max. absorption:** 2.5 A
- Net weight:** 3000 g (with power supply cord)
- Total weight (with packing box):** 4700 g
- Electric cable length:** 1.5 mt (with no plug)
- Minimum brightness for working operations:** LUX 200
- Vibrations at start up:** < 2.5 m/sec²
- Temperature range:** 0 – 55 C
- Umidity range:** 10 – 95% without condensate

BLADES AVAILABLE:

12SHSS, 120 mm 8-edges, HSS steel | **12CHSS**, 120 mm circular, HSS steel | **12DHSS**, 120 mm 12-edges, HSS steel | **12SHSSTF**, 120 mm 8-edges, HSS steel Teflon® coated | **12SHSSTN**, 120 mm 8-edges, HSS steel Titanium coated | **12DHSSTN**, 120 mm 12-edges, HSS steel Titanium coated | **12SMD**, 120 mm 8-edges, Carbide (Widia®)



Tube

PETRONI SRL
Via A.Bucchi, 1/B
06012 Città di Castello (PG)
+39 075/852.07.87

www.petronisrl.it